

For Those Who Do the Dirty Work

Present your guests with unparalleled comfort and hospitality with UltraLav® mobile restrooms & showers.



Shower Combo Trailers

UltraLav® mobile shower trailers are configured to provide your customers with the ultimate convenience of both a shower and toilet in a comfortable, private setting. Constructed with durable and low-maintenance components, your UltraLav will provide years of carefree service. UltraLav® showers are offered in 2-stall and 3-stall models.



INTERIOR

- 48" x 26" Shower Pan
- Metered Water Saver Chrome Shower
- Metered Water Saver Chrome Sink Faucet
- Shower Curtain
- Fiberglass Sink
- Shatter Proof Mirror
- Soap Dispenser
- Paper Towel Dispenser
- Toilet Paper Holder
- Ceramic Pedal Flush Toilet
- Wastebasket
- Sanitary Supply Receptacle
- Smooth, Aluminum PolyCor® Interior Walls & Ceiling
- Non-Skid Black Rubber Coin Floor
- 12v LED 6" Round Dome Lights (4 per)

MECHANICALS

- Roof Mounted A/C with Heat Strip
- Wall Mounted Thermostat
- On-Board Fresh Water System (105 Gallons)
- Fresh Water Pump
- 6 Gallon Electric Water Heater
- PEX Manifold Water Distribution System
- 120V 30 amp Motorbase with Twist Lock
- 120V 30 amp 25' Shoreline
- Polyethylene Waste Tank (3/8" Walls)
- White Vinyl Walls In Mechanical Closet



EXTERIOR

- Fold-Up Steps with Hand Rail
- Wall Mounted Aluminum Railings
- 12v LED Porch Lights
- 3" Quick Connect Waste Tank Valve
- Waste Tank Level Indicator (Sight Glass)
- City Water Hook-Up
- Scissor Jacks



Standard Shower Room



- Popular Options**
- Winterization Package
 - Propane Water Heater Package
 - Aluminum Wheels

Private Stall Mobile Showers

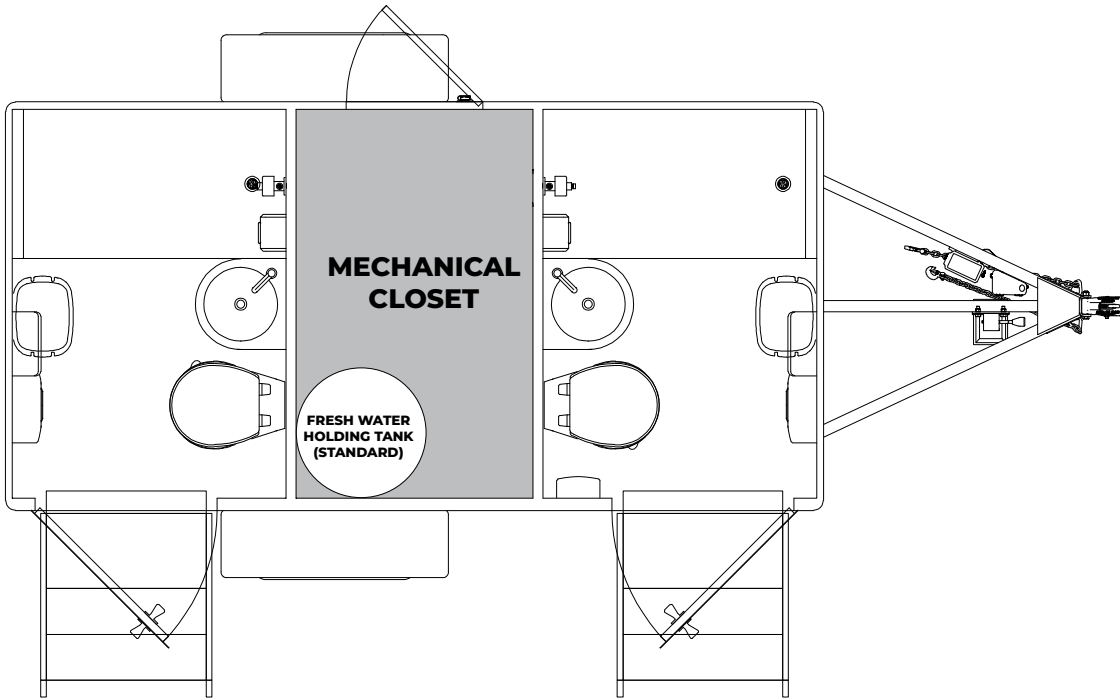

2-Stall Shower Combo Trailer

Model: UL612-2-S
Body Size: 6'W x 12'L
Tank Capacity: 240 gal

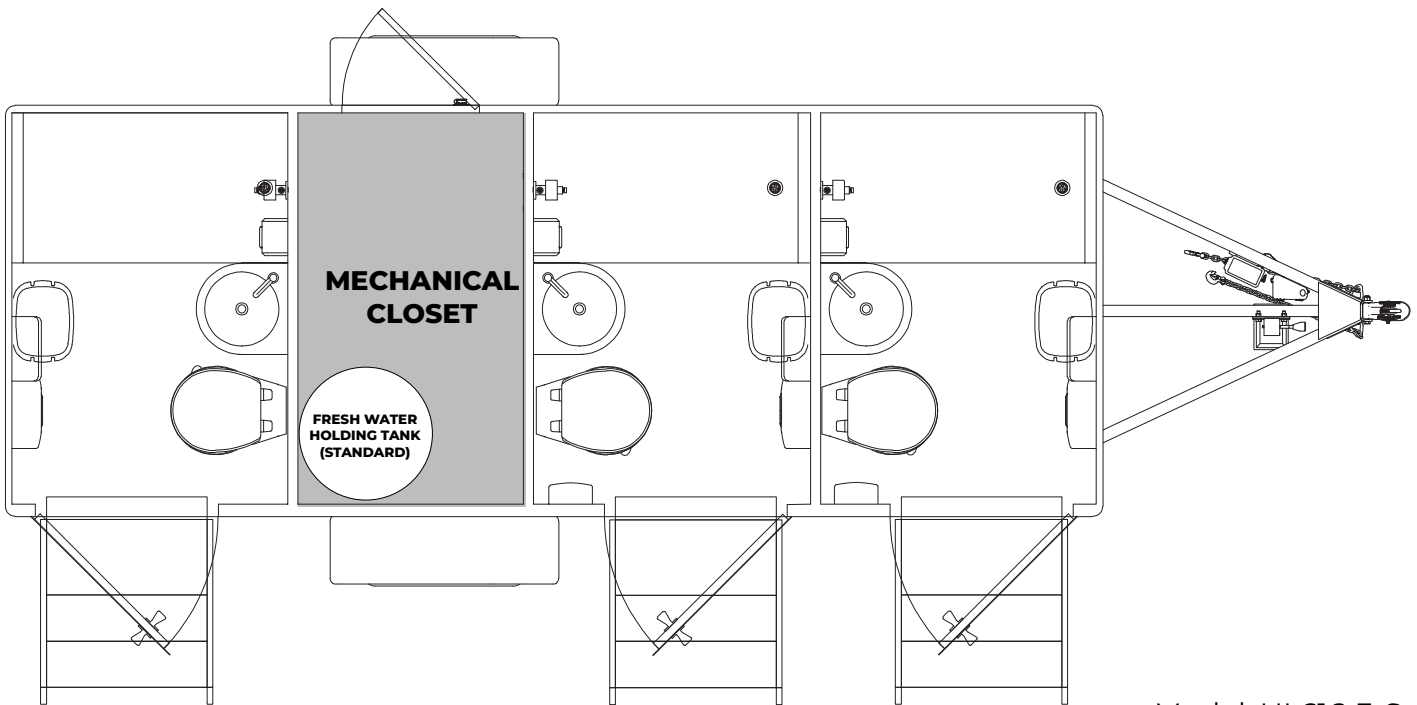

3-Stall Shower Combo Trailer

Model: UL616-3-S
Body Size: 6'W x 16'L
Tank Capacity: 325 gal

